

N028032A

Rev. 0 - 10/06/2022

U-CAN TOUCH WATER WAND WITH INTEGRATED SENSOR

WATER WAND

- swinging support
- integrated thermocouple type K Ø 2 mm g.c.insulated
- pipe Ø 12 mm AISI 304
- water separator

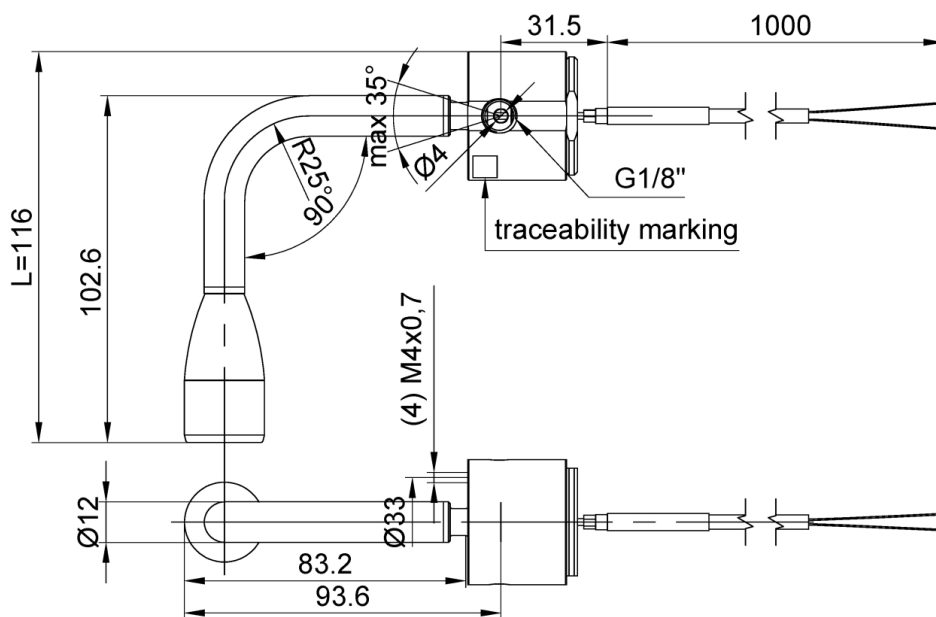

TECHNICAL SPECIFICATION

wand tube	Ø 12 mm
tube material	AISI 304
Sheath length L	116 mm
Fixing system	a flangetta through-wall connection
Contact food type	ACQUA/VAPORE
FCM Prescriptions	Before the use is required to wash the food contact areas
Thermocouple calibration	type K (cromel-alumel)
Number of sensing elements (T/C) (*) (* Number Elements (T/C) asterisco	single
Hot measuring joint	insulated
Sensing part maximum working temperature	100°C
Cable extension E	1 m
Cable conductors	tipo K
Norm of reference	IEC 584
Number of cable conductors	2
Conductor dimension	AWG 26
Conductor feature	strand (19 wire)
Primary insulation	PFA
Secondary insulation	PFA
Cable size or external shape	about Ø 2,2 mm
Cable working temperature	-50 ÷ 260°C
Product type	Traditional Cable
FCM Prescriptions	Before the use is required to wash the food contact areas
Contact food type	ACQUA
Type of contact	short and frequently
Contact food temperature range	0 ÷ 100°C
Notes for FCM	la LANCIA ACQUA è idonea al contatto con ACQUA fino a 100°C (se presente aeratore plastico sino a 70°C)