

L033026C

Rev. 1 - 10/06/2022

HOT WATER DISPENSER WITH STAINLESS STEEL AERATOR

- ball joint \varnothing 14,3 mm in CW510L BRASS (T.E.A. treatment)
 - G 3/8 cap in CW510L BRASS (T.E.A. treatment)
 - stainless steel water separator
- supplied components: spring, spring guide and O-ring seal.

Materials used in compliance with the application and reference standards for contact with foodstuffs.

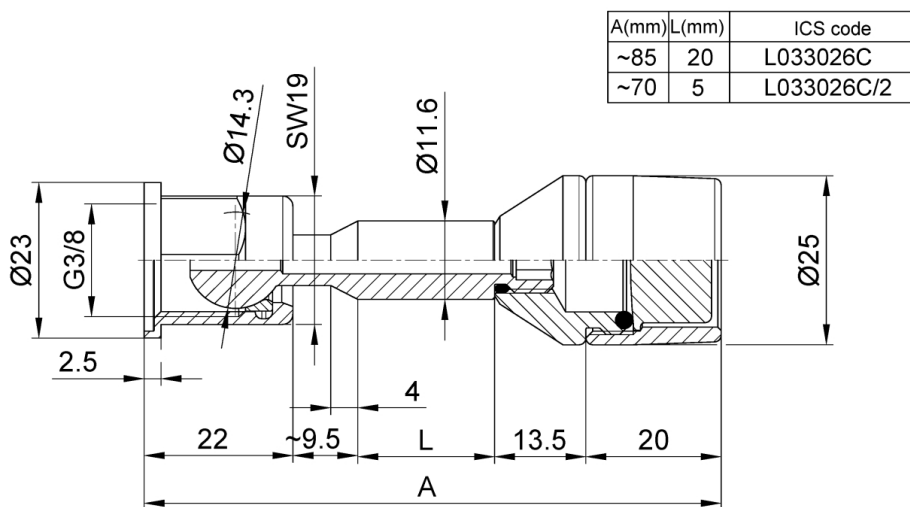

TECHNICAL SPECIFICATION

Sheath length L	5 mm 20 mm
Sheet material	OTTONE CW510L rivestito T.E.A.
Sheath diameter d	Ø 11.6 mm
Threaded process connection (*) (* Thread STANDARDS (CYL. GAS in accordance with UNI-ISO 228) (CON. GAS in accordance with UNI-ISO 7-1) (NPT in accordance with ANSI B 1.20.1)	3/8" GAS CIL.
Fixing system	threaded connection
FCM Prescriptions	Before the use is required to wash the food contact areas
Contact food type	ACQUA
Type of contact	short and frequently
Contact food temperature range	0 ÷100°C
Notes for FCM	la LANCIA ACQUA è idonea al contatto con ACQUA fino a 100°C (se presente aeratore plastico sino a 70°C)